

Operating manual



TruTool N 500 (1A1)

english

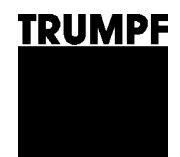

Table of Contents

1.	Safety	4
1.1	General safety information.....	4
1.2	Specific safety information.....	5
2.	Description	6
2.1	Correct use	7
2.2	Technical data	8
3.	Setting work	9
3.1	Changing the stroke rate	9
3.2	Selecting the tool	10
4.	Operation	12
4.1	Working with the TruTool N 500.....	12
4.2	Changing the cutting direction	14
4.3	Nibbling with templates.....	15
4.4	Making inner cutouts.....	15
5.	Maintenance	16
5.1	Replacing the tool	17
5.2	Disassembling the punch.....	18
5.3	Installing the punch.....	18
5.4	Changing the die and the punch guide.....	18
5.5	Regrinding the punch.....	19
5.6	Replacing carbon brushes	20
6.	Original accessories and wearing parts.....	21

Guarantee

Spare parts list

Addresses

1. Safety

1.1 General safety information

USA/CAN ➤ Read the operating manual and the safety information (order no. 1239438, red document) in their entirety before starting up the machine. Closely follow the instructions given.

Other countries ➤ Read the operating manual and the safety information (order no. 125699, red document) in their entirety before starting up the machine. Closely follow the instructions given.

➤ Adhere to the safety regulations in accordance with DIN VDE, CEE, AFNOR and to the specific regulations of the country of operation.



Danger

Risk of fatal injury from electric shock

- Pull the plug from plug socket before undertaking any maintenance work on the machine.
 - Check the plug, cable and machine for damage each time before using the machine.
 - Keep the machine dry and do not operate it in damp rooms.
 - Connect the earth leakage (EL) circuit breaker with a maximum release current of 30 mA when using the electric tool outside.
-



Warning

Risk of injury due to improper handling.

- Wear safety glasses, hearing protection, protective gloves and work shoes when working at the machine.
 - Do not insert the plug unless the machine is switched off. After use, pull out the power plug.
-

1.2 Specific safety information



Warning

Risk of injury to hands

- Do not reach into the processing line with your hand.
 - Use both hands to hold the machine.
-



Caution

Damage to property due to improper handling!

Machine will be damaged or destroyed.

- Do not use the power cable to carry the machine.
 - Always lay the electrical cable away from the back of the machine and do not pull it over sharp edges.
 - Have servicing and inspections of hand-held electric tools carried out by a qualified specialist. Only use original accessories provided by TRUMPF.
-



Warning

Risk of injury from hot and sharp chips!

Hot and sharp chips are emitted from the chip dumping at high speed.

- The use of a chip bag is recommended.
-



Warning

Risk of injury from falling machinery!

The entire weight of the machine must be taken up after processing of the work workpiece.

- Use suspension eyelet with balancer.
-

2. Description

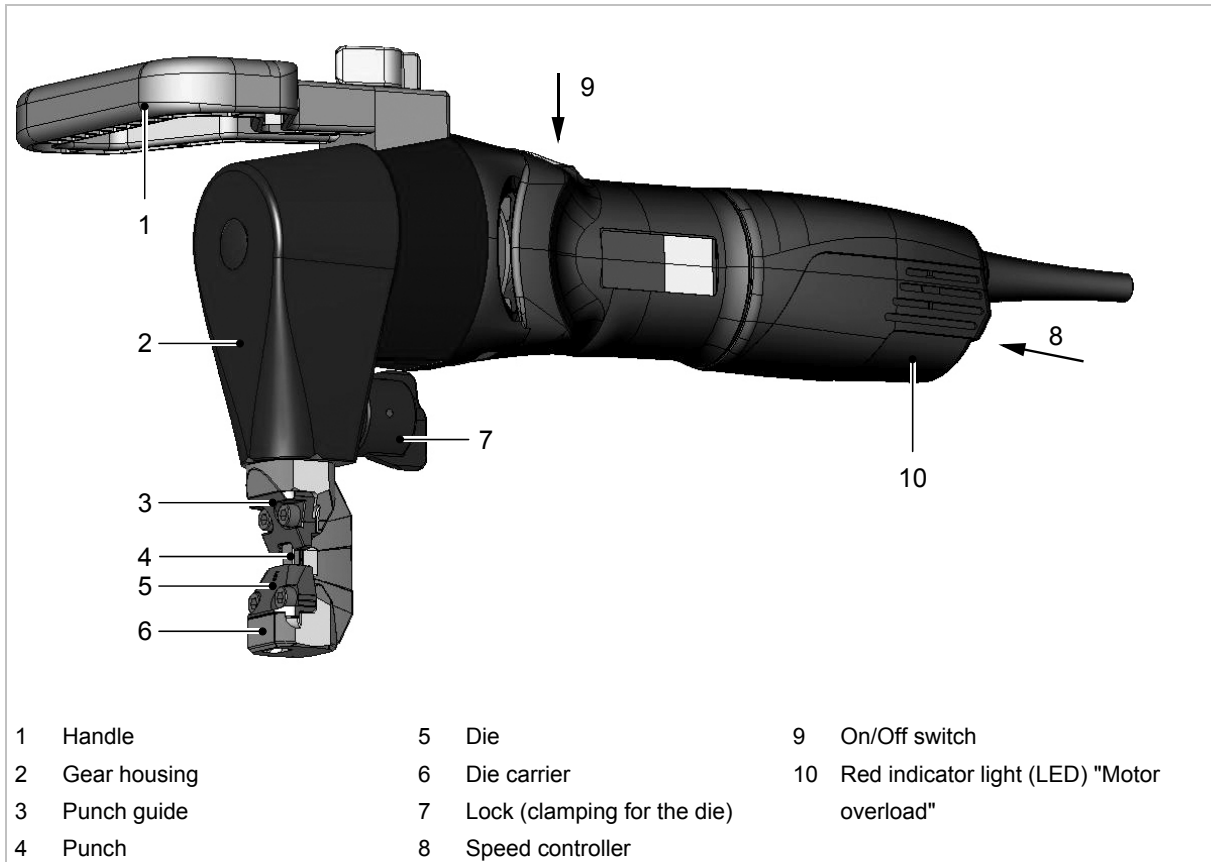

Nibbler TruTool N 500

Fig. 52771

2.1 Correct use



Warning

Risk of injury

- Only use the machine for work and materials described in "Intended use".

The TRUMPF Nibbler TruTool N 500 is a handheld electric tool used for the following applications:

- Slitting plate-shaped workpieces made of a punchable material such as steel, aluminum, non-ferrous heavy metals, and plastic.
- Slitting of tubes and machining of edged sheet profiles and/or press brake bendings, e.g. for tanks, crash barriers, troughs, etc.
- Nibbling straight or curved exterior and interior cutouts.
- Nibbling along scribed lines or templates.

Note

The nibbling process produces cutting edges free of deformations.

2.2 Technical data

	Other countries			USA
	Value	Value	Value	Value
Voltage	230 V	120 V	110 V	120 V
Frequency	50/60 Hz	50/60 Hz	50/60 Hz	50/60 Hz
Max. material thickness:				
• Steel 400 N/mm ² .	5.0 mm	5.0 mm	5.0 mm	0.2 in
• Steel 600 N/mm ² .	3.2 mm	3.2 mm	3.2 mm	0.125 in
• Steel 800 N/mm ² .	2.5 mm	2.5 mm	2.5 mm	0.1 in
• Aluminum 250 N/mm ² .	7 mm	7 mm	7 mm	0.28 in
Working speed	1.5 m/min	1.5 m/min	1.2 m/min	4.3 ft/min
Nominal power consumption	1400 W	1200 W	1140 W	1200 W
Idle stroke rate	725/min	650/min	650/min	650/min
Weight	4.0 kg	4.0 kg	4.0 kg	8.9 lbs
Cutting track width	8 mm	8 mm	8 mm	0.31 in
Start hole diameter for die	41 mm	41 mm	41 mm	1.6 in
Sheet profile 90° bending radius inside	8 mm	8 mm	8 mm	0.31 in
Smallest radius with curved cuts	90 mm	90 mm	90 mm	3.54 in
Protective insulation	Class II	Class II	Class II	Class II

Technical data

Table 1

Vibration	Specifications in accordance with EN 12096 Measured values in accordance with EN ISO 8662-10
Vibration value at the handle a	14.9 m/s ²
Uncertainty K	2.15 m/s ²

Table 2

Measured values were measured while machining sheet steel 400 N/mm² with max. material thickness.

Noise emissions	Specifications in accordance with EN ISO 4871 Measured values in accordance with EN ISO 15744
A-rated sound level L _{WA}	84 dB
A-rated acoustic power level at the work place L _{PA}	95 dB

Table 3

The noise emission values given are the sum of the measured values and the corresponding uncertainties. They represent an upper value limit which can emerge during measurements.

3. Setting work

3.1 Changing the stroke rate

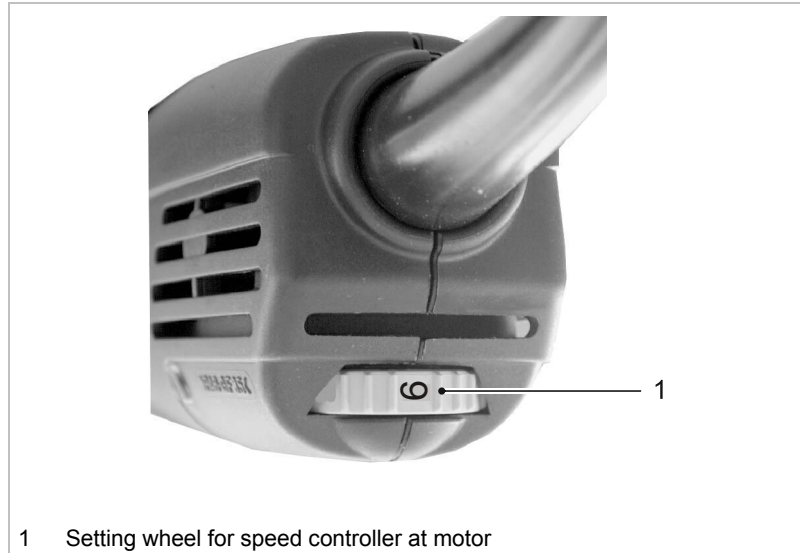

Fig. 27948

A reduced number of strokes improves the quality of the work







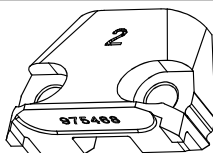

- For precise machining along scribed lines.
- For machining radiuses.
- For machining steel with a tensile strength $> 400 \text{ N/mm}^2$ (improved service life).

3.2 Selecting the tool

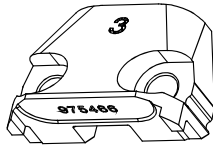
Tensile strength of the workpiece	Acceptable material thickness
Mild steel up to 400 N/mm ²	5 mm
Stainless steel up to 600 N/mm ²	3.2 mm
Stainless steel up to 800 N/mm ²	2.5 mm
Aluminum up to 250 N/mm ²	7 mm

Table 4

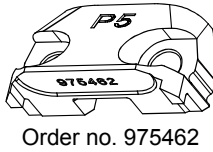
Certain material thicknesses can be machined, depending on the workpiece type.

Material thickness [mm]		Type of die	Type of punch
Single rolled sheet	Sectional sheet		
1-2	1	 <p>Order no. 975468</p>	 <p>Order no. 1453187</p>
2-3.2	1-2	 <p>Order no. 975466</p>	 <p>Order no. 1453187</p>
3-5	2-3	 <p>Order no. 975464</p>	 <p>Order no. 1451224</p>
5-7	3-5	 <p>Order no. 975462</p>	 <p>Order no. 1451224</p>

Selecting type of die and punch

Table 5

Use the die with the greatest feasible height

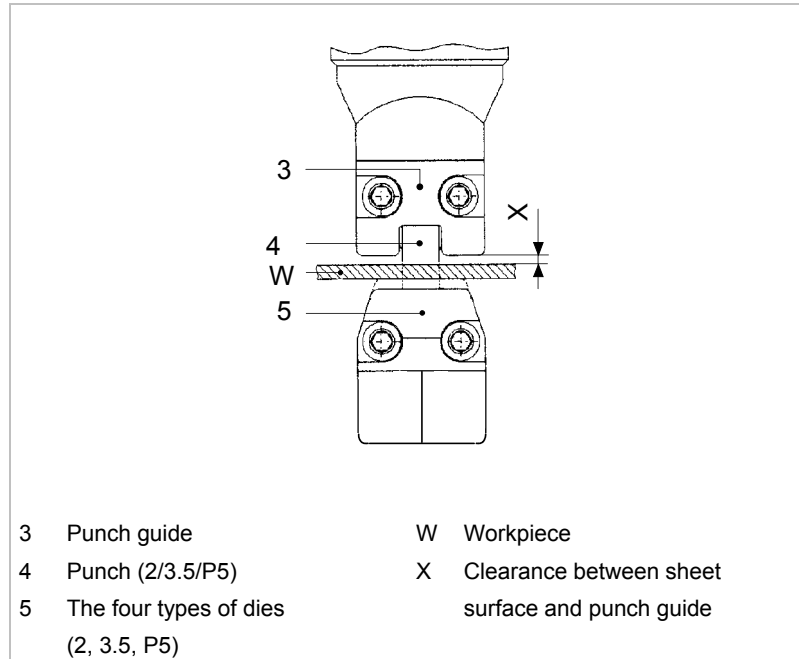

Clearance between die and punch guide

Fig. 52810

Note

The distance between the sheet surface and the punch (x) must remain as small as possible.

Does severe back-and-forth movement (hammering) occur during the cutting process?

The reason is an unsuitable die. Excessive tool wear and increasing loads on the machine are the result.

- Use the die with the greatest feasible height.

4. Operation

4.1 Working with the TruTool N 500



Caution

Damage to property due to high power-supply voltage!

Motor damage.

- Check the line voltage. The power-supply voltage must correspond to the information on the nameplate of the machine.
-



Warning

Risk of injury due to improper handling.

- Make sure the machine is always in a stable position when operating it.
 - Never touch the tool while the machine is running.
 - Always move the machine during work away from your body.
 - Do not operate the machine above your head.
-

Electromagnetic interference

The appliance may switch off prematurely when affected by electromagnetic interference. The appliance will resume operation when the faults have been cleared.

Motor overload protection

If the motor temperature is too high, the motor will switch off. The red indicator light (LED) with the motor lights up.

- Allow the machine to run in idle until it has cooled down.

The machine can be operated again normally after it has cooled down.



Switching on and off

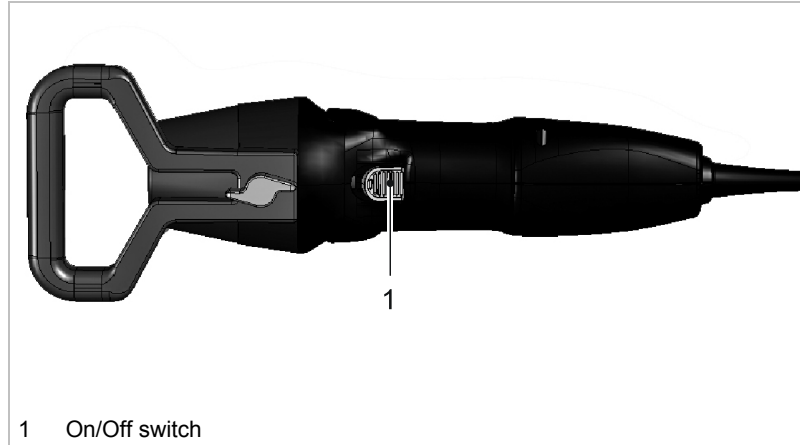

Fig. 52403

Switching on the TruTool N 500

- Push the on/off switch forward until it locks into place.

Working with the TruTool N 500

1. Do not move the machine towards the workpiece until full speed has been reached.
2. Machine the material.
 - Machine the desired cutting line
3. In the event that the cutting track ends in the sheet, pull the still-running machine a few millimeters back towards where the cutting track has already been cut open.
4. Switch off machine.

Switching off the TruTool N 500

- Push the rear part of the on/off switch.

Note

The cutting result is improved and the service life of the punch increased if the cutting track is coated with oil before machining the workpiece.

Material	Oil
Steel	Punching and nibbling oil (0.5 l, order no. 103387)
Aluminum	Wisura oil (1 l, order no. 125874)

Table 6

4.2 Changing the cutting direction

In situations where space is limited, the tool and/or the cutting direction can be turned by 90° to the right, to the left, or by 180° (see Fig. 52772, p. 17)

1. Open locking mechanism (9).
2. Rotate die carrier (7) by 90° or 180° in the desired direction.
3. Close locking mechanism (9).

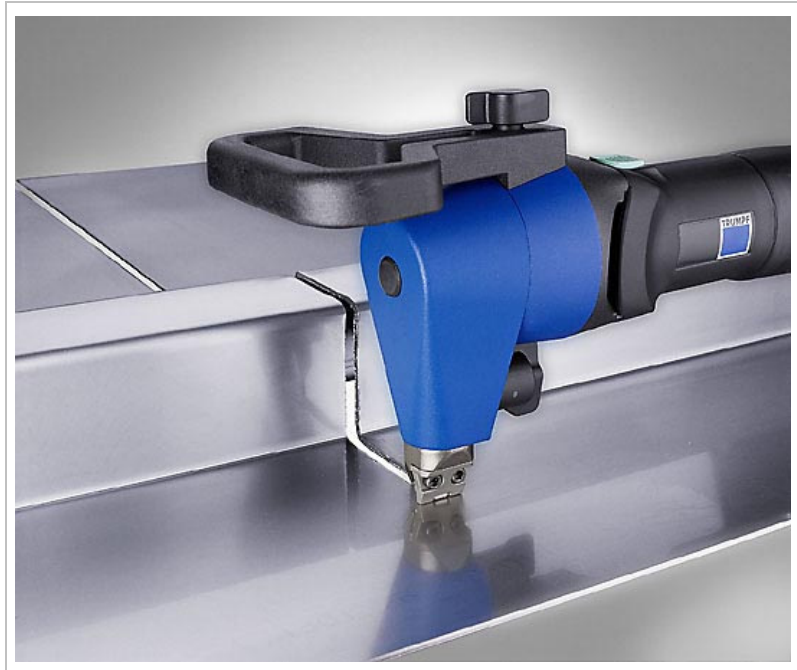

Cutting profiles

Fig. 52794

4.3 Nibbling with templates

The following requirements must be met when nibbling with templates:

- The template must be at least 3 mm thick.
- The contour of the template must have a clearance of 8.5 mm to the contour to be nibbled out.
- Observe a minimum radius of 90 mm on the workpiece.
- The nibbler is to be guided in such a way that the punch guide is always up against the template.

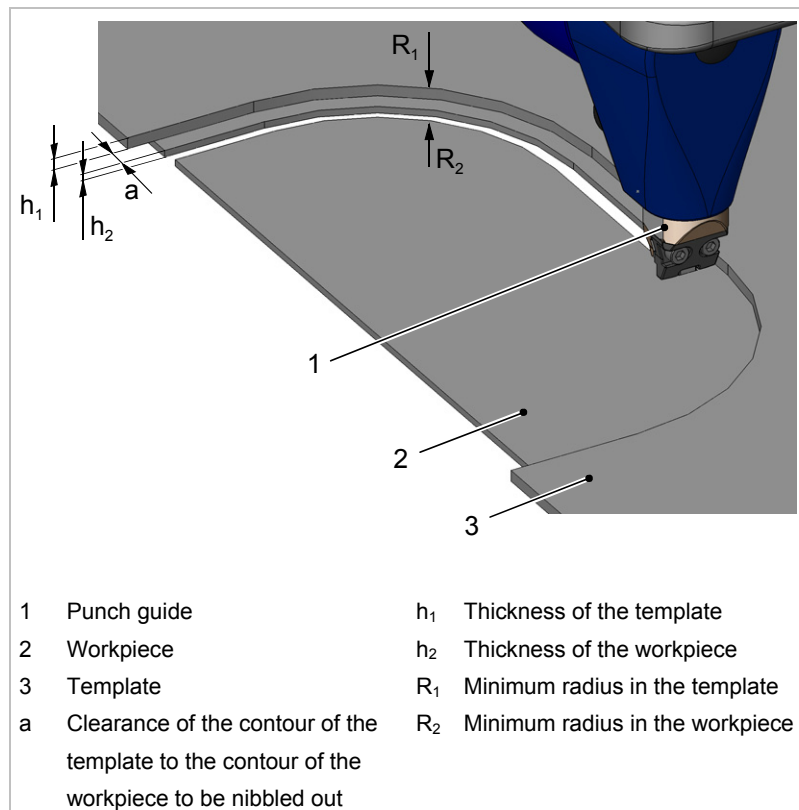

Fig. 52793

4.4 Making inner cutouts

- Make a start hole at least 41 mm in diameter.

5. Maintenance



Caution

Damage to property caused by blunt tools!

Machine overload.

- Check the cutting edge of the cutting tool hourly for wear. A sharp punch provides good cutting performance and is easier on the machine. Replace or regrind the punch promptly.



Warning

Risk of injury due to repair work not being carried out properly!

Machine does not work properly.

- Repair work may only be carried out by a qualified technician.

Maintenance point	Procedure and interval	Recommended lubricant	Lubricant order no.
Punch	Regrind as needed (see section 5.5, p. 19)	-	-
Punch	Change as needed (see section 5.1, p. 17)	-	-
Ventilation slots	Clean as needed	-	-
Die	Replace as necessary	-	-
Punch and die carrier	With each tool change	Lubricating grease "G1"	0344969
Gearbox and gear head	After 300 operating hours, arrange for a qualified technician to relubricate or to replace the lubricating grease.	Lubricating grease "G1"	0139440

Maintenance points and maintenance intervals

Table 7

5.1 Replacing the tool

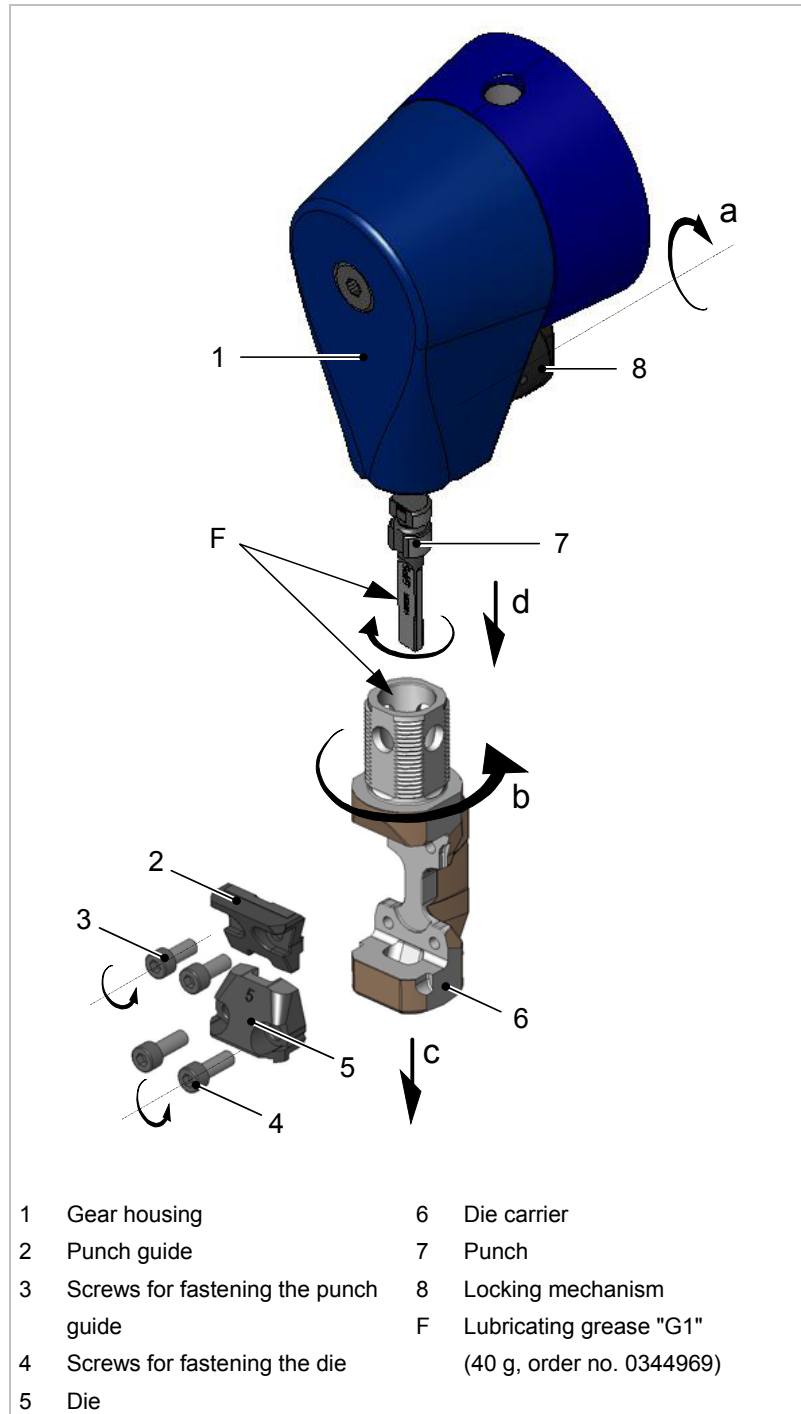

Fig. 52772

- If the punch or die becomes blunt, sharpen the punch or change the tool.

5.2 Disassembling the punch

1. Open locking mechanism (8).
2. Rotate the die carrier (6) by 45°.
3. Pull die carrier (6) out towards the bottom.
4. Turn punch (7) until it can be pulled out.

5.3 Installing the punch

1. Lightly lubricate the square part of the punch (7) and bore hole on the die carrier (6) with lubricating grease "G1" (order no. 0344969).
2. Rotate the punch (7) to the 45° position.
3. Connect the die carrier (6).
4. Make the locking mechanism (8) engage.

5.4 Changing the die and the punch guide

1. To replace the die and the punch guide, unscrew the fixing screws (3 and 4).
2. Clean the support areas on the die carrier (6).
3. Take care to ensure that the replacement parts are clean.
4. Lubricate the guide surfaces of the punch guide with lubricating grease "G1" (order no. 0344969).
5. Screw the fastening screws tightly when mounting the die and the punch guide (torque 9 Nm). Use original screws only.

5.5 Regrinding the punch

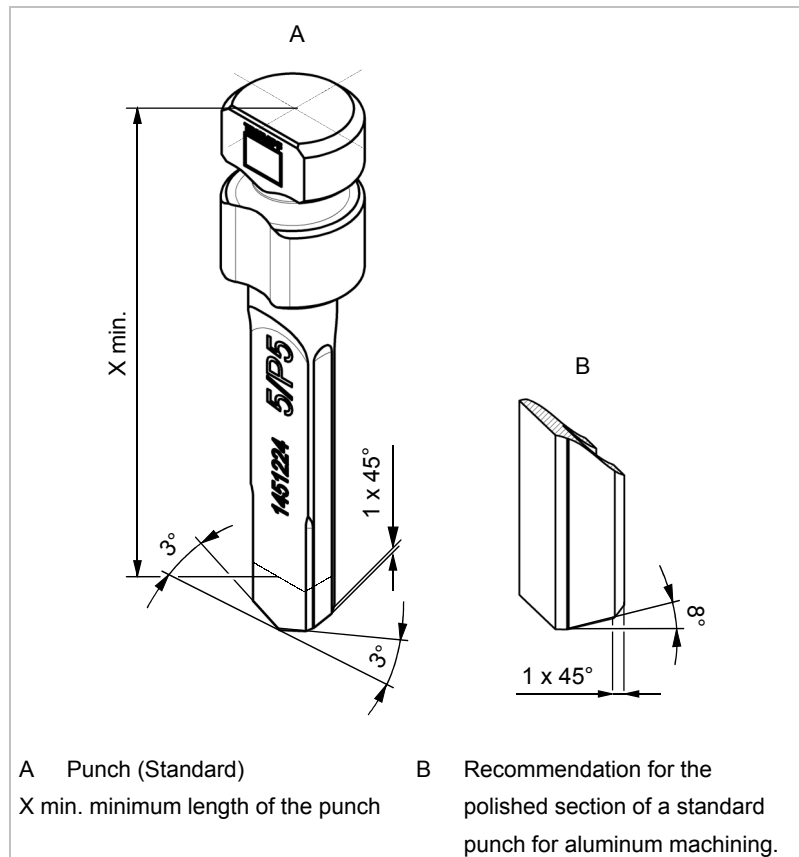

Fig. 52773

The punch can be reground, depending on the die with which it is utilized

Note

Dies can not be resharpened.

1. Regrind the grinding surface, making sure that it is well-cooled during the process.
2. Lightly apply fine-grained oil stone to the cutting edge.
3. Observe the minimum length (X min.) while grinding.
4. Replace shorter punches.

Punch	Die	Regrinding reserve of the punch	Minimum length (X min.) of the punch
5/P5	P5	0.5 mm	58.8 mm
5/P5	5	2.8 mm	56.5 mm
2/3 ¹	2, 3	-	-

Table 8

¹ This type of punch cannot be reground.



5.6 Replacing carbon brushes

The motor comes to a standstill whenever the carbon brushes are worn out.

- Have the carbon brushes checked and replaced as required by a qualified specialist.

Note

Only use original replacement parts and observe the specifications on the type plate.

6. Original accessories and wearing parts

TruTool N 500	Supplied original accessories	Wearing parts	Options	Order no.
Handle, complete	+			0974659
Allen key DIN 911-4	+			0067849
Lubricating grease "G1" can (40 g)	+			0344969
Case	+			0982540
Operating manual	+			1453364
Safety information (red document), other countries	+			125699
Safety information (red document), USA	+			1239438
Punch 5/P5		+		1451224
Punch 2/3		+		1453187
Die 2		+		0975468
Die 3		+		0975466
Die 5		+		0975464
Die P5		+		0975462
Chip bag			+	0103557
Punching and nibbling oil for steel (1 l)			+	0103387
Punching and nibbling oil for aluminum (1 l)			+	0125874
Suspension eyelet			+	0097208

Table 9

Ordering original parts and expendable parts

To ensure the correct and fast delivery of original parts and wearing parts:

1. Specify the order number.
2. Enter further order information:
 - Voltage data
 - Quantity
 - Machine type
3. Provide complete shipping information:
 - Correct address.
 - Desired delivery type (e.g. air mail, courier, express mail, ordinary freight, parcel post)
4. Send the order to the TRUMPF representative office. Refer to the address list at the end of the document for TRUMPF service addresses.

